

NOTE:  
THIS DRAWING INDICATES AND ASSUMES THE USE OF  
A MINIMUM OF 0.5MM CSA PER CORE.

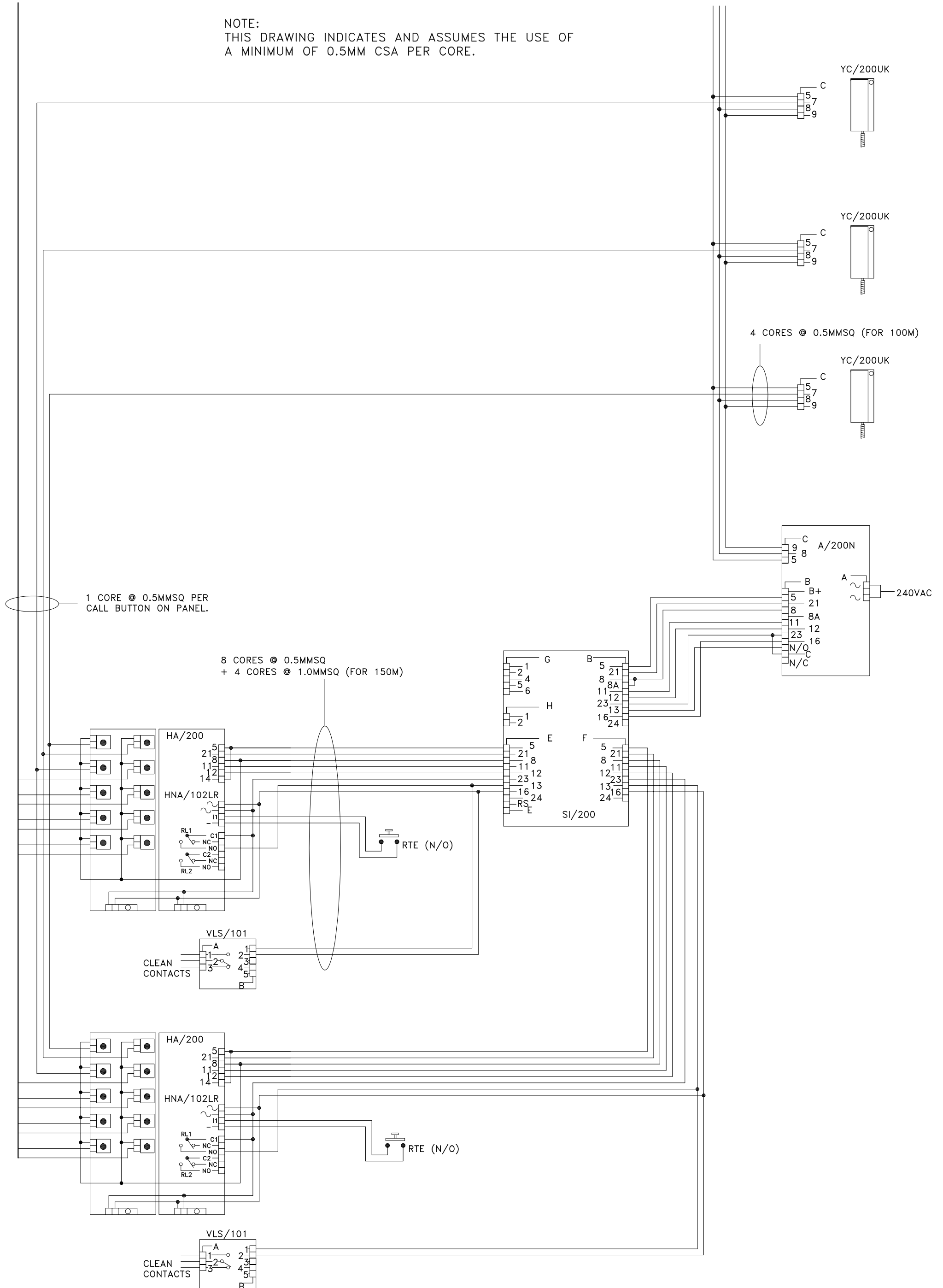

<p>BPT (UK) LTD. HERTS. ENGLAND</p>	<p>PREPARED FOR INSTALLER INFORMATION</p>	<p>DATE: 28/07/05</p>	<p>DRAWN:RC</p>
<p>DRAWING TITLE: 2 X MULTI-BUTTON TARGHA AUDIO ENTRY PANELS WITH HNA/102 KEYPADS, CLEAN CONTACT RELAYS &amp; LYNEA HANDSETS</p>		<p>REVISED: DRAWING No: E-NT2YNCK</p>	